



SUA-110M4x-x-S235

Shell Material :

Blank : BRASS

I : SPCC

Color :

White : W

Black : B

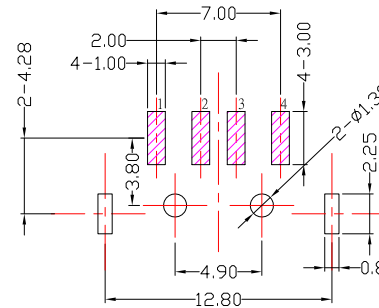
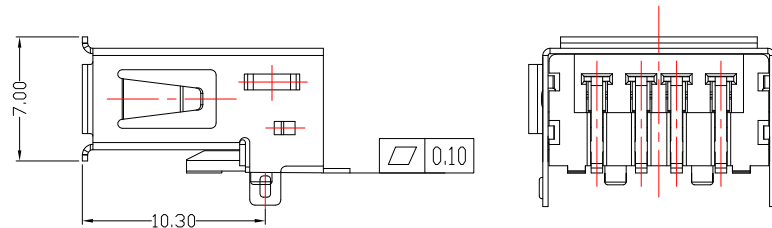
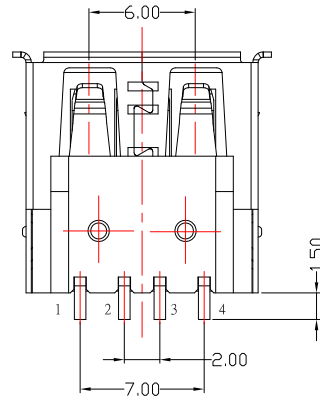
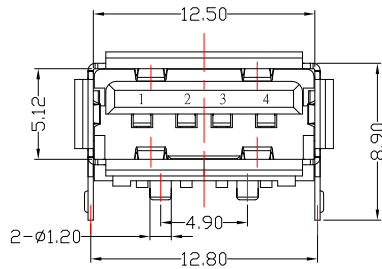
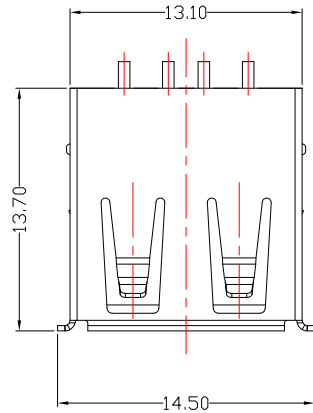

RECOMMENDED PCB LAYOUT

SPECIFICATIONS

Electrical:

- 1.Contact Resistance: 30 mΩ Max
- 2.Insulation Resistance: 1,000 MΩ Min
- 3.Dielectric Withstanding Voltage: 500 V AC

Material:

- 1.Housing: LCP , UL 94V-0
- 2.Contact: Phosphor Bronze
- 3.Shell: Brass / SPCC

Finish:

- 1.Contact: Plated Gold in Mating Area ;
Tin Plated on Solder Balls ;
Nickel under plated overall
- 2.Shell: Nickel under Plated surface layer

ITEM NO.	DESCRIPTION	DRAWN	DATE
3	新增PIN編號	Jack	072120
2	新增PCB LAYOUT尺寸	Jack	072020
1	新增半整度標示	Jack	052518



TOLERANCE UNLESS OTHERWISE STATED :

Up to 5 ±0.2
Above 5 ~ 15 ±0.3
Above 15 ~ 30 ±0.4
Above 30 ~ 50 ±0.5
Angle ±0.3°

3RD. ANGEL'S



UNITS

MM

DRAWN BY:	DATE
Jack Lu	07/21/20
CHECKED BY:	DATE
Jacky Chen	07/21/20
APPROVED BY:	DATE
Tony Kao	07/21/20

MAT'L	TITLE	CONNECTOR
	MODLE	USB A/F SMT 外殼直腳 有柱
SCALE	1 : 1	DWG NO. SUA-110M4x-x-S235
SHEET NO.	1 of 1	PART NO. SUA-110M4x-x-S235
		SIZE A4
		VER R3